

Data Sheet

> Specifications

Chicanes comprise two (2) structures placed so as to constrain users to slow down, installed especially near road and paths intersections

- Welded tubes with polyester powder-coating and H.I. grade reflective sheeting strips
- Removable Locking System with Pin and Padlock, which fastens Post to the Base, to facilitate emergency operations
- Standard dimensions (2-arms chicanes) :
Overall 1000 x 1000 mm (39.38 x 39.38 in)
Central post dia. 102 x thick. 5.7 mm (dia. 4 x thick. 7/32 in)
Variable arms length, maximum 900 mm (35.43 in)
- Installation on a Welded-plate Ground Anchor (900 mm), painted Uptek (black) steel, with four (4) 1/2-13 tapped holes
- Option : Cover Plate for Ground Anchor, once the base is removed for winter seasonal operations



> Locking System

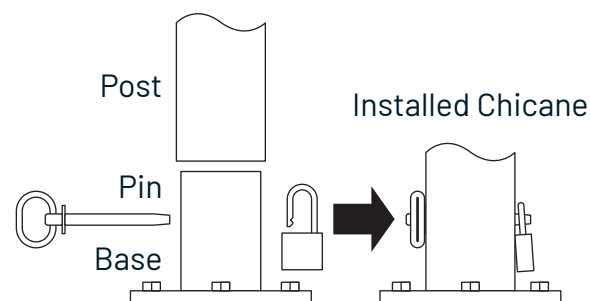

> Overview

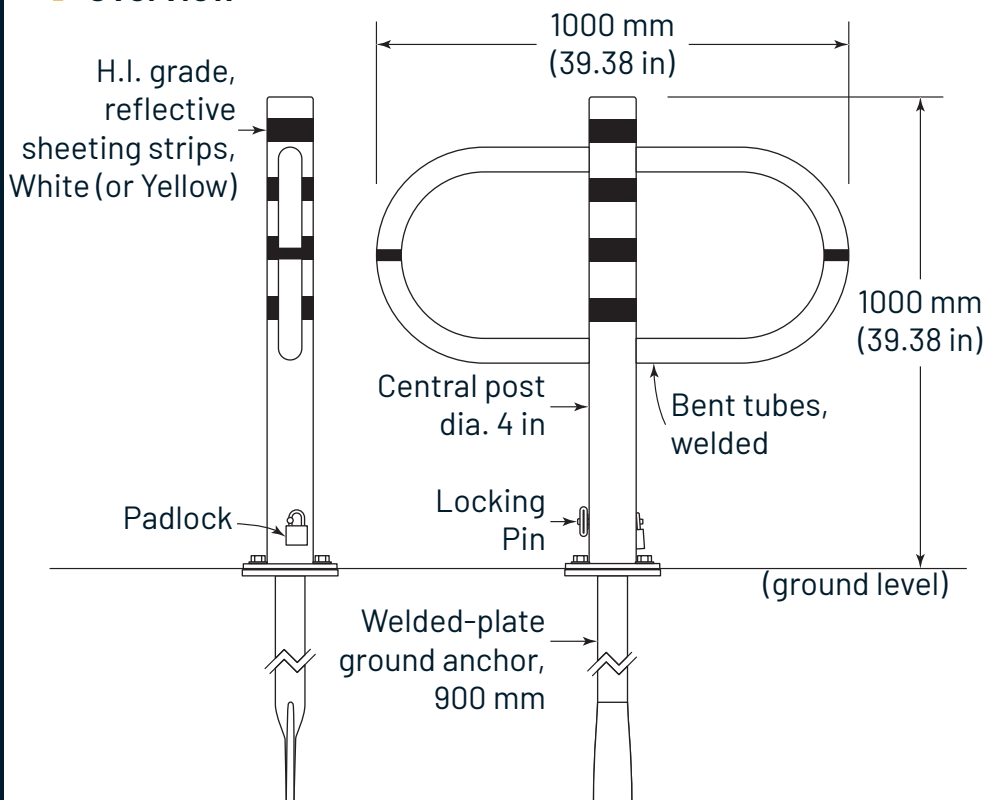

> Cover Plate

